

21724 - 4 Pockets

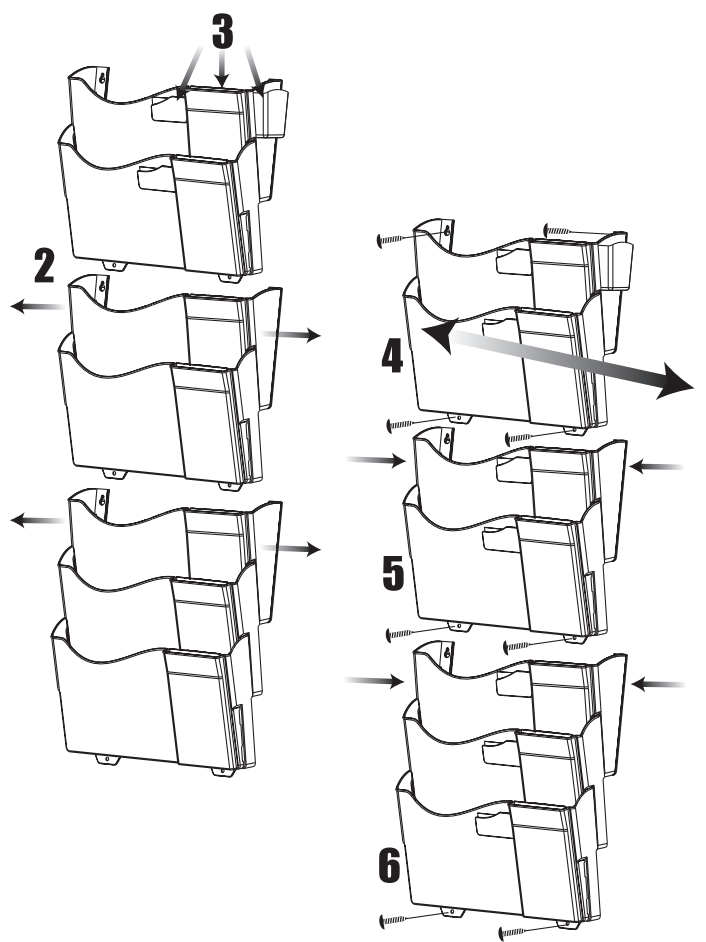







1. All pockets will come pre-assembled for ease of shipping, however some additional assembly is required.
2. Disassemble the top 2 pockets from the bottom 2 pockets by gently pulling apart from the ends of the third pocket.
3. Install pencil cup, plastic label covers and envelope compartment dividers following instructions above for 21720 and 21722 for all pockets.
4. Attach initial two pockets on wall and then mark position for 4 screw holes, drill holes as marked and install anchors.
5. Re-attach the initial two pockets on wall and tighten the screws to secure.
6. Attach the bottom two pockets to the above installed pockets and follow the steps of above 4 and 5 to complete the installation.



21726 - 7 Pockets

1. All pockets will come pre-assembled for ease of shipping, however some additional assembly is required.
2. Disassemble the top 2 pockets, the next 2 pockets and the bottom 3 pockets by gently pulling apart from the ends of the third and the fifth pockets.
3. Install pencil cup, plastic label covers and envelope compartment dividers following instructions above for 21720 and 21722 for all pockets.
4. Install initial two pockets following the instructions of step 4 & 5 of 21724.
5. Install the next 2 pockets following the instructions of step 6 of 21724.
6. Install the bottom 3 pockets following the instructions of step 6 of 21724.

Parts List for Wall File Assembly

Description	Assembly	21720	21722	21724	21726	21728
 Pencil Cup	by user	1		1	1	1
 Label Holder	by user	1	1	4	7	4
 Envelope Divider	by user	1	1	4	7	4
 Back Plate for Starter Pocket	pre-installed					1
 Back Plate for Add-on Pocket	pre-installed		1	3	6	3
 Hanger Set (Pair)	by user					1
 Anchors	by user	4	2	6	8	6
 Screws	by user	4	2	6	8	6

Officemate.

90 Newfield Avenue
Edison, NJ 08837
Tel: 732-225-7422
Fax: 732-225-6466
www.officemate.com
Made in USA